

---

# Ecoflo Treadle Pump

---

PROPOSAL FOR  
GUARANTEED UPLIFTMENT OF MARGINAL FARMERS



Website: [www.ecofloindia.com](http://www.ecofloindia.com)

---

*Manufactured by: Bhinge Brothers, Nashik*

The present rural scenario anywhere in the backward areas of the world.....	3
The Solution.....	3
The Aim.....	3
<b>Ecoflo Treadle Pump .....</b>	<b>4</b>
<i>Distinct Features .....</i>	<i>5</i>
<i>Analysis of the Ecoflo Treadle pump .....</i>	<i>6</i>
<i>The Proposal .....</i>	<i>8</i>
<i>Awards and Achievements .....</i>	<i>9</i>
<i>Case Studies.....</i>	<i>10</i>
<i>NGO Associations .....</i>	<i>11</i>
<i>Technical Specifications.....</i>	<i>12</i>
<i>Material Specifications .....</i>	<i>12</i>
<i>Treadle Pump Accessories Specifications .....</i>	<i>13</i>
<i>Frequently Asked Questions .....</i>	<i>14</i>

# The present rural scenario anywhere in the backward areas of the world

Electricity to most is a lifeline today. But there are many such people in India and abroad who still live with less or no electricity. Considering one set of people- the agricultural farmers, there is no one line to sum up the importance of agriculture in any country. Agriculture is the backbone or perhaps the only source of livelihood for the rural people. This is more so for backward, remote and interior areas which are quite far away from the rural areas situated nearby big town and cities. Such backward areas are even devoid of electricity or the power is for only for namesake. All the inhabitants are poor and marginal farmers who do farming with the primitive methods depending on the natural and seasonal rainfall. They can only grow seasonal crops during the rains for some part of the year. **Rest of the year they are helpless and idle and this pushes them towards further poverty.**

*“Give a man a fish, and you feed him for a day. Teach a man to fish, and you feed him for a lifetime.”*

*–Anne Isabelle*

## The Solution

Proper irrigation is the only solution for the upliftment of these marginal and poor farmers so that they can do farming for the maximum period in a year. Water from nearby natural sources like rivers, lakes, ponds.etc can also be brought and stored for irrigation in the water storage reservoirs made as above. This was only possible by the use of electrical pumpsets or diesel powered pumps or Solar pumps. All the above options are beyond the means of the marginal farmers. A simple cost effective solution with no recurring cost was needed. The development of the Ecoflo Treadle pump fitted perfectly into the scenario. These pumps are light and portable -so that a farmer can carry it anywhere on his shoulders- place it near any water source and pump water to a distance of upto even 500mtrs through low cost pipes or trenches and then irrigate his field. Micro irrigation kits in different types as per the requirements can also be used for irrigating the small farms as a further enhanced upgraded option

## The Aim

To ensure that the farmer/user gets introduced to a means of irrigating his small land holding even during the dry season that would generate him additional yields. Once he realizes the potential of growing and reaping profits in the dry season – he then finds his way to prosperity. The Ecoflo Treadle pump is just a simple means to introduce the marginal farmer to irrigate his small landholding in the dry season that would generate him additional yields and uplift to the next level. Further he should not come across any kind of hindrance or trouble during the extensive/ prolong use of the Treadle pump.

# Ecoflo Treadle Pump

Developed, Patented under patent registration no: 210928 dt. 3-12-07



**Treadle pumps** are in use from a very long time, but only in improvised versions.

The Basic Treadle Pump consists of two metal cylinders with pistons that are operated by a natural walking motion on two treadles.

The pump's low cost makes it accessible to even very poor farmers who can use it to grow dry-season vegetables for home consumption and for sale. Since 1985, when some

NGOs first began promoting the treadle pump in Bangladesh, about two million treadle pumps have been installed worldwide. These are suited for manually irrigating small land holdings of one hectare or less. Treadle pumps has significant advantages over motorized pumps for irrigation of agricultural land of less than one hectare. This is less expensive than motorized pumps. Costs much less to operate, having no fuel and practically no maintenance. Most importantly it can be used in inaccessible and remote places with no electricity, near any water source. With the user's body weight and leg muscles in a comfortable walking motion, the use of the pump can be sustained for extended periods of time without excessive fatigue. The treadle pump is much less tiring than other manual pumps that utilize the upper body and relatively weak arm muscles with much lower discharge.

# *Distinct Features*

The Ecoflo pump developed and Patented by Nasik (India) based Bhinge Brothers, follows the same basic principle of the reciprocating suction pump but with the following distinct features:

- ♣ The pump manifold and fittings, cylinders and pistons are all made from injection molded engineering durable thermoplastic with close tolerances and with every component designed with ribs and reinforced sections to meet the most stringent conditions of wear and tear.
- ♣ The whole unit including the fabricated structure is portably designed in such a way that it weighs just 12kgs so a person weighing 60 kg should easily carry the unit, then should be able to suck upto 500lph water from upto 7mtrs depth and pump it to a level upto 15mtr. a pressure enough to run a drip / sprinkler irrigation system or to transfer water to long distances upto 500mtrs.

♣ The pump has a metal frame structure to support the thermoplastic “Cylinder-Piston manifold block assembly” in the firm position. The hollow steel powder coated frame

structure is designed in such a manner that the plastic molded assembly doesn't require to be bolted or fixed. It is secured perfectly in place protected from mechanical strains.

- ♣ The piston design and the mounting of the rubber gaskets is aimed to get minimum frictional losses.
- ♣ No operating cost. Simple & effortless pedaling/stepping motion.
- ♣ Very efficient design to give best results with minimum muscle power.



# *Analysis of the Ecoflo Treadle pump*

## *The Frame Structure*

It is the main part of the pump and is made of hollow mild steel section. It forms about 40% cost of the pump. It is very easy for any steel fabricator to make this structure if necessary in bigger quantity if the demand is high. This will not only create entrepreneurship in remote areas but also generate employment for many. This however needs development of special jigs and fixtures for mass production with special electric arc welding machines. Also a set of centre lathe machines for pins and bushings. The fabricated structure then needs to be powder coated to prevent corrosion. If powder coating facility is not available then it can be suitably hand painted with some good corrosion proof paint too.

The option of utilizing local units for developing MS frame structures for the Treadle pump is only to be exercised only after the initial phase of implementation when the generated demand is more than 2000 units per area per year. Additionally the fabricator will need the plastic end caps, handle grips, the centre handle spacer and the centre pulley to complete the structure.



## *The complete set of plastic molded Cylinders, pistons, piston rods and manifold assembly with inlet and outlet connections*

All components needed for the same are injection molded on Hi tech machines using specially developed tooling . The Plastic raw material needed is such that it is durable and long lasting with special uv additives for use in sunlight with the required strength that it should not normally ever break in usage. The parts are also easily replaceable.

These components are mass produced and assembled in house and are guaranteed against any manufacturing defect. These constitute about 40% of the pump cost. The patent for the Ecoflo treadle Pump has been specifically granted for the development of this assembly in Plastic – replacing the ms steel fabricated cylinder piston and manifold assembly. This is the heart of the pump and will be exclusively made available by Bhinge Brothers- Nasik.



## *The Suction and Delivery Pipe*

The suction and the delivery pipe constitute 20% of the pump cost. The suction pipe normally given with the pump is 7-8 mtrs. It is just a PVC braided/spiral suction pipe that is available almost everywhere in shops and manufactured in almost every part of India. This pipe is cheap and works well for 1-2 years in the sunlight and can be easily replaced by the farmer.

The delivery pipe – It is to be used for delivery of water to a distance of upto 25mtrs. It is made specially in Polyethylene (PE) suitably uv stabilized for long life. It can be replaced or the length of it can be increased with any pipe available locally. It is provided as a standard accessory and comes in layflat wounded compact roll of 25 mtrs .



## *The foot valve, connectors and spanner*

The foot valve is specially developed such that suction of sedimented bottom soil or dirt is avoided. Foot valves are also available locally as these are also used with other pumps and hence can always be replaced if necessary.

The barbed connectors as seen in the picture are available in 40mm and 50mm to be fitted on the suction and the delivery side of the manifold respectively. 40mm barbed connector is also used for fitting onto the special foot valve. These are proprietary items not available anywhere in the market.



The molded plastic spanner is also provided with every pump unit. It is necessary for de-threading the pump cylinder – only in extreme conditions when the pump does not work .

It also has the provision in centre for tightening or loosening the centre bolt that fixes the handle of the pump.

## *The nylon rope*

The rope as used in the pump is actually a monofilament plastic rope with very high strength. This rope is prone to wear after long use and need s to be replaced . Being multi use -it is available easily in every locality.

# *The Proposal*

It is seen that the Ecoflo Treadle pump is made from such material that apart from the cylinder piston and manifold assembly, everything else can be procured locally.

Initially the company intends to supply complete units to the designated areas of operation.. However the user has the liberty to:

Buy additional/ replacement pipes from local shops to enhance the use of the pump.

Furthermore , when if the demand for a particular area increases substantially the possibility of making use of the local fabricators/ entrepreneurs to develop the complete treadle pump

with all the plastic components and cylinder piston manifold assembly unit from the parent unit. This will not only generate local employment but will help repair and servicing with distribution at localized areas.

The complete unit including all accessories is so much reasonably priced that it would be really difficult for anyone to develop the frame structure . But for a sustainable and ongoing program – local intervention is necessary by way of service centers initially and local manufacturers/ fabricators at a later stage.



Employing local people to help distribute and educate the proper use and the benefits of the Treadle pump should be the key for the success of any program.

Further the option to provide opportunities for growth and employment should be made available to the local to make them entrepreneurs by helping them to set up fabrication and complete assembly using only knowhow with the main plastic components and assemblies from the principal manufacturer.

# Awards and Achievements



Winner of Plastindia foundation **Plasticon-2005** award towards Excellence in contribution to agriculture



Winner of most prestigious Marico Innovation for India Award-2008 in the business for social sector



Mr. Bill Clinton himself endorsing the pump for a fund raising event for iDE ( International Development Enterprises) in USA

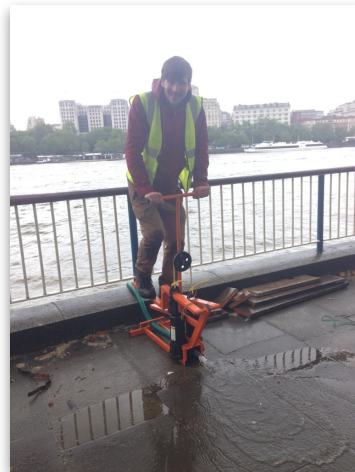

International Presence in Africa, U.K and U.S.A



# Case Studies

## *Story of Ashakiranwadi - Visit by Dr. A.P.J Abdul Kalam*

In 2005, a remote village called Vaitagwadi in Igatpuri was given our few treadle pumps along with basic drip irrigation system by renowned NGO -BAIF Mitra. One of the poor farmer wrote a post card to the then President of India Dr.A.P.J.Abdul Kalam to please come and visit them to see and replicate this model across India for rural upliftment. Dr. Abdul Kalam actually visited-saw and was impressed and changed the name of the village to Ashakiranwadi. The story does not end here -the same villagers came and bought more similar sets with their own resources. And just a few months back the Sarpanch(Head) of this village comes in his car to buy another set to help uplift another remote village



TV Clip of the Ashakiranwadi Visit

## *One of the Success stories of Mokhada, Jawhar*

Last year a generous man from Mumbai Mr. Amir Gilani came to a very poor but known village- Mokhada near Jawahar. He introduced a similar model consisting of low cost water reservoir being filled from a nearby lake and basic treadle pump irrigation complete kits. This year ongoing the villagers are coming in groups every week to buy drip irrigation



systems for their farms directly from our factory. This clearly implies their understanding of profits from such model. This village will no longer be called a poor village just within a year or so.

# *NGO Associations*

## *International NGOs*

- iDE (International Development Enterprise)
- Red Cross
- UN Funded Projects
- FAO (Food and Agriculture Organisation)
- USAID
- Winrock International
- NARI EU-ARD Project
- Relief Society Tigray (REST)
- ActionAid
- Total Land Care
- Practica Foundation

## *Indian NGOs*

- BIAF MITTRA
- Pradan
- Swades Foundation
- IIT Powai
- CARDS
- SHARE
- Foundation for Ecological Society
- CSA (Center for Sustainable Agriculture)
- RAIDCO Kerala Ltd.
- Center for Experimental Earning
- And many more..

# Technical Specifications

Unit weight	13.5- 14 kgs without accessories
Maximum Piston stroke	180mm
Optimum operator human being	60 kgs
Maximum operator weight permissible	90kgs
Optimum output 1 mtr depth and 12.5mtrs ground	5000ltrs per hour
Maximum permissible operating depth	6mtrs
Maximum operating head	14mtrs
Expected gasket life	1500 operating hours or 5 years whichever earlier
expected rope life	300 operating hours or 5 years whichever earlier

# Material Specifications

Item	Size	Mtrl of Cons.	Qty	Specifications
Cylinder	90mm ID - 200mm length	Engg Plastic	2	UV Stabilised with additives for minimum friction
Piston	90mm Dia	Engg Plastic	2	With 2 grooves for sealing gaskkets
Piston Seal	90mm Dia	Rubber	4	Nitrile Rubber cup type
Manifold box		Engg Plastic	1	With 1.5" inlet & outlet threads ports
Valve flaps		Rubber	4	Nitrile Rubber
Valve flaps holding assly		Engg Plastic	4	
Steel frame structure	1-1.2mm thickness	MS steel		Cold rolled hollow steel sections
Steel frame structure protective coating				
Rope	8mm thick	Poly propylene	1	Monofilament rope

# Treadle Pump Accessories Specifications

Suction Pipe Soft PVC with rigid PVC spiral	40mm I.D 3-3.5mm thickness 6-8kg/cm.2 pressure.
Delivery Pipe LLDPE Plain	50mm I.D 0.8mm thickness -Max working pressure 2kg/cm <sup>2</sup>
Foot Valve	Polypropylene plastic - UV Stabilised with 40mm/1.5" threaded connector
40mm/1.5" Threaded Connector	Polypropylene plastic - UV Stabilised
50mm/1.5" Threaded Connector	Polypropylene plastic - UV Stabilised, for connecting 50mm LLDPE Plain Pipe
Maximum Piston stroke	180mm
Optimum operator human being	60kgs
Maximum operator weight permissible	90kgs
Optimum output 1 mtr depth and 12.5mtrs ground	5000ltrs per hour
Maximum permissible operating depth	6mtrs
Maximum operating head	14mtrs
Expected gasket life	1500 operating hours or 5 years whichever earlier
Expected rope life	300 operating hours or 5 years whichever earlier
Expected life of Plastic components	5 years

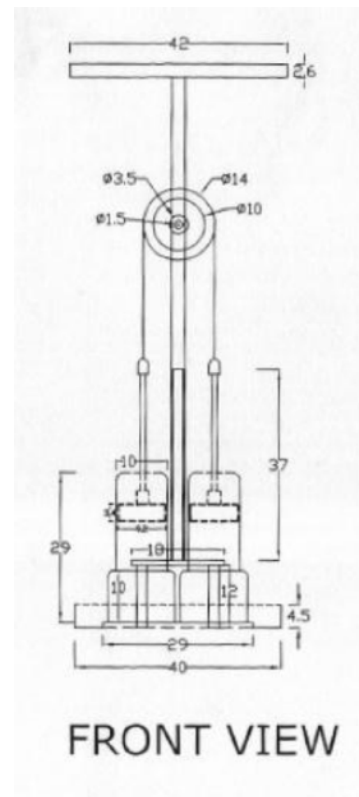
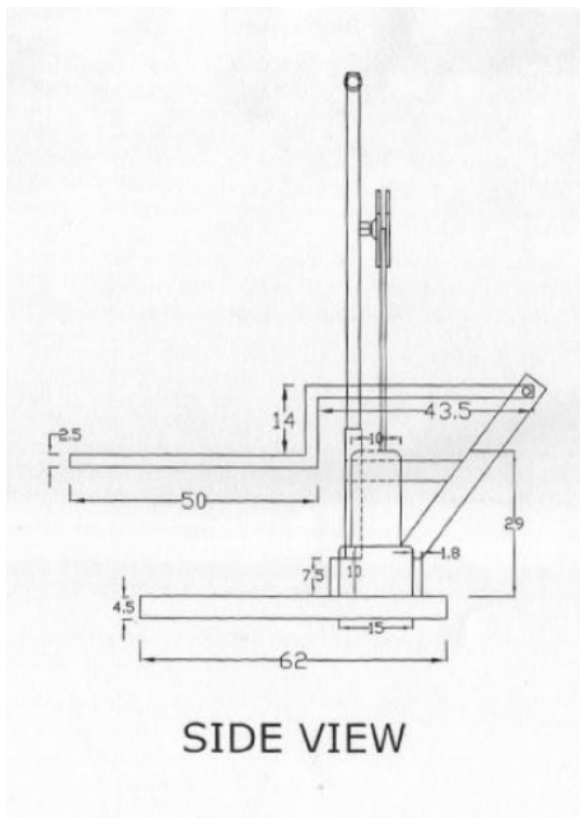

# *Frequently Asked Questions*

## *1. Why Ecoflo Treadle Pump?*

- The Ecoflo Treadle pump is a foot operated pump- the lightest pump of its kind in the world . Its cylinder piston and manifold assembly are made is special uv stabilized engineering plastic to make it light and to make it very smooth in operating.

## *2. What are the operating parameters of the pump?*

- The maximum suction depth is 7 mtrs and the maximum delivery head is 15 mtrs expected from a person weighing 60 kgs. It is not recommended for person weighing beyond 90 kgs as the structure is designed for maximum weight of 90 kgs only. However more depth and delivery heads have been practically achieved in the field by actual users

## *3. What care needs to be taken while operating the pump?*

- The only care that needs to be taken while operating the pump is that piston rod top rocker assly position is properly in place provided on the treadles and the treadle is parallel to the ground when a person is standing on it. This is to be achieved by adjusting the tied knots of the plastic rope. Under no circumstances should the rope be short -that the piston hits the top of the cylinder- that may severely damage the pump.

## *4. What should I do if the pump becomes rough in operation?*

- Oil preferably coconut or any edible oil can be applied inside the cylinder walls to make this pump smooth to operate. In fact it is recommended that this oiling is to be done on the inside of the cylinder walls as often as possible to make the pump longer lasting with extremely smooth operation. Grease or any lubricant should be avoided as it may make the water non potable.

## *5. What should I do if no water comes out of the delivery pipe?*

- The pump needs to be operated by person with full continuous strokes for a few minutes till the water fills into the delivery pipe. Care is to taken that there is no air leaking inside into the top nipple connection of the suction pipe. The foot-valve is such designed that it avoids the bottom sediment/dirt /soil of water body to get sucked. It also has a non return flap valve inside such that the water does not easily flow back into the reservoir. The foot-valve can also be sometimes activated if the pump is idle for a long time by rocking it up and down in the water to help the rubber flaps inside. In rare case sometimes - the complete suction pipe sometimes needs to be filled with water and pump operated to help

activate any stuck rubber flaps inside the manifold assembly of the pump which may have got stuck due to some foreign matter.

## *6. What is the expected life of the pump?*

- The Ecoflo Treadle pump has been developed keeping the poor farmers in mind and is made with practically no possible breakage/ failure of any component such that it easily lasts for atleast 2 years till the farmer gets enough and satisfactory benefits from its use. The 1st sign of overuse that would be seen will be -external on the fabricated mild steel structure mainly on the treadle pin bush assly which can be easily restored by any local fabricator. Also the plastic rope that gets worn out and is available locally. The suction pipe provided is 7-8 mtrs length- is made in pvc with a limited life in the sun and is easily available locally for any replacement. The delivery pipe is however uv stabilised and is roll-able such that it can be used to transport water for 25mtrs or more. It can be replaced and extended with any pipe available locally.